

4" Straight Section

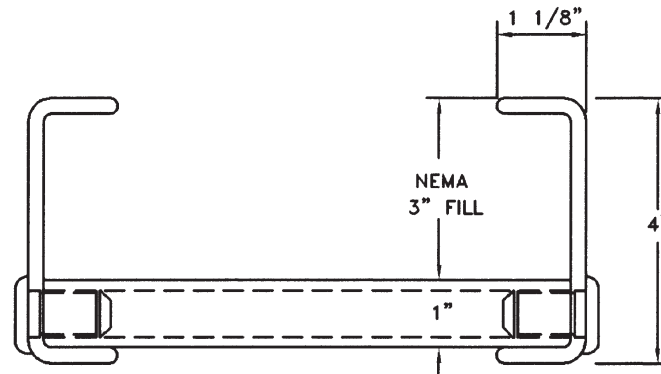

Side Rail Height: 4" (NEMA 3" loading depth)

Widths: 6", 9", 12", 18", 24", 30", 36"

Rung spacing: 6", 9", 12", 18"

Length: 120" [10'] or 240" [20']

Splice Plates: One pair of splice plates with SS6 (316 Stainless Steel) hardware included.

Seasafe Series	Safety Factor
4	1.5

Loading - NEMA 12C *tested per NEMA FG-1, 12" rung spacing

4" Horizontal Bends

-R- Bend Radius in.	Tray Width in.	90° Horizontal Bend Dimensions		
		Catalog No.	A in.	B in.
12	6	(Prefix)-06-90HB12	20 3/8	20 3/8
	9	(Prefix)-09-90HB12	21 7/8	21 7/8
	12	* (Prefix)-12-90HB12	25 1/4	25 1/4
	18	* (Prefix)-18-90HB12	28 1/4	28 1/4
	24	* (Prefix)-24-90HB12	31 1/4	31 1/4
	30	* (Prefix)-30-90HB12	34 1/4	34 1/4
	36	* (Prefix)-36-90HB12	37 1/4	37 1/4
24	6	* (Prefix)-06-90HB24	34 1/4	34 1/4
	9	(Prefix)-09-90HB24	35 3/4	34 3/4
	12	* (Prefix)-12-90HB24	37 1/4	37 1/4
	18	* (Prefix)-18-90HB24	40 1/4	40 1/4
	24	* (Prefix)-24-90HB24	43 1/4	43 1/4
	30	(Prefix)-30-90HB24	46 1/4	46 1/4
	36	(Prefix)-36-90HB24	49 1/4	49 1/4
36	6	(Prefix)-06-90HB36	46 1/4	46 1/4
	9	(Prefix)-09-90HB36	47 3/4	47 3/4
	12	(Prefix)-12-90HB36	49 1/4	49 1/4
	18	(Prefix)-18-90HB36	52 1/4	52 1/4
	24	(Prefix)-24-90HB36	55 1/4	55 1/4
	30	(Prefix)-30-90HB36	58 1/4	58 1/4
	36	(Prefix)-36-90HB36	61 1/4	61 1/4

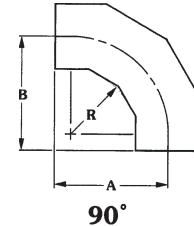

4" System

-R- Bend Radius in.	Tray Width in.	45° Horizontal Bend Dimensions			
		Catalog No.	A in.	B in.	C in.
12	6	(Prefix)-06-45HB12	22 13/16	9 7/16	14 3/4
	9	(Prefix)-09-45HB12	23 7/8	9 7/8	15 15/16
	12	* (Prefix)-12-45HB12	17 7/8	7 3/8	10 7/16
	18	* (Prefix)-18-45HB12	20	8 1/4	11 11/16
	24	* (Prefix)-24-45HB12	22 1/16	9 1/8	12 15/16
	30	* (Prefix)-30-45HB12	24 3/16	10	14 3/16
	36	* (Prefix)-36-45HB12	26 5/16	10 15/16	15 7/16
24	6	* (Prefix)-06-45HB24	24 3/16	10	14 3/16
	9	(Prefix)-09-45HB24	25 1/4	10 1/2	16 3/4
	12	* (Prefix)-12-45HB24	26 5/16	10 15/16	15 7/16
	18	* (Prefix)-18-45HB24	28 7/16	11 13/16	16 11/16
	24	* (Prefix)-24-45HB24	30 9/16	12 11/16	17 15/16
	30	(Prefix)-30-45HB24	32 11/16	13 9/16	25 1/2
	36	(Prefix)-36-45HB24	34 13/16	14 7/16	27 15/16
36	6	(Prefix)-06-45HB36	32 5/8	13 1/2	20 1/2
	9	(Prefix)-09-45HB36	33 11/16	13 15/16	21 11/16
	12	(Prefix)-12-45HB36	34 3/4	14 3/8	22 15/16
	18	(Prefix)-18-45HB36	36 7/8	15 1/4	25 7/16
	24	(Prefix)-24-45HB36	39	16 3/16	27 15/16
	30	(Prefix)-30-45HB36	41 1/8	17 1/16	30 7/16
	36	(Prefix)-36-45HB36	43 1/4	17 15/16	32 7/8

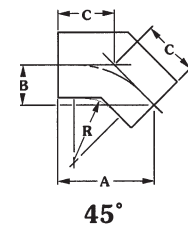

Note: Dimensions for reference only, when critical contact factory.

4" Vertical Bends

-R- Bend Radius in.	Tray Width in.	Catalog No.	Vertical Bend - 90°			
			Vertical Outside Bend		Vertical Inside Bend	
			A in.	B in.	A in.	B in.
12	6	* (Prefix)-06-90(*)12	19 1/4	19 1/4	23 1/4	23 1/4
	9	* (Prefix)-09-90(*)12				
	12	* (Prefix)-12-90(*)12				
	18	* (Prefix)-18-90(*)12				
	24	* (Prefix)-24-90(*)12				
	30	* (Prefix)-30-90(*)12				
36	* (Prefix)-36-90(*)12					
24	6	(Prefix)-06-90(*)24	31	31	35 1/2	35 1/2
	9	(Prefix)-09-90(*)24				
	12	(Prefix)-12-90(*)24				
	18	(Prefix)-18-90(*)24				
	24	(Prefix)-24-90(*)24				
	30	(Prefix)-30-90(*)24				
36	(Prefix)-36-90(*)24					
36	6	(Prefix)-06-90(*)36	43	43	48 1/2	48 1/2
	9	(Prefix)-09-90(*)36				
	12	(Prefix)-12-90(*)36				
	18	(Prefix)-18-90(*)36				
	24	(Prefix)-24-90(*)36				
	30	(Prefix)-30-90(*)36				
36	(Prefix)-36-90(*)36					

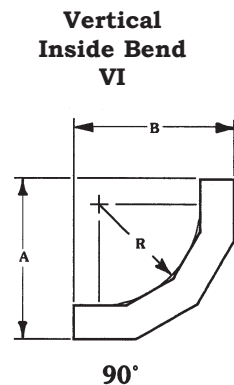
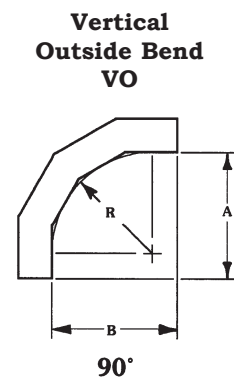

-R- Bend Radius in.	Tray Width in.	Catalog No.	Vertical Bend - 45°					
			Vertical Outside Bend			Vertical Inside Bend		
			A in.	B in.	C in.	A in.	B in.	C in.
12	6	* (Prefix)-06-45(*)12	13 5/8	5 5/8	8	16 7/16	6 13/16	6 13/16
	9	* (Prefix)-09-45(*)12						
	12	* (Prefix)-12-45(*)12						
	18	* (Prefix)-18-45(*)12						
	24	* (Prefix)-24-45(*)12						
	30	* (Prefix)-30-45(*)12						
36	* (Prefix)-36-45(*)12							
24	6	(Prefix)-06-45(*)24	20 1/2	8 1/2	12 11/16	23 5/16	9 11/16	13 11/16
	9	(Prefix)-09-45(*)24						
	12	(Prefix)-12-45(*)24						
	18	(Prefix)-18-45(*)24						
	24	(Prefix)-24-45(*)24						
	30	(Prefix)-30-45(*)24						
36	(Prefix)-36-45(*)24							
36	6	(Prefix)-06-45(*)36	20 1/2	8 1/2	13 11/16	23	9 11/16	13 11/16
	9	(Prefix)-09-45(*)36						
	12	(Prefix)-12-45(*)36						
	18	(Prefix)-18-45(*)36						
	24	(Prefix)-24-45(*)36						
	30	(Prefix)-30-45(*)36						
36	(Prefix)-36-45(*)36							

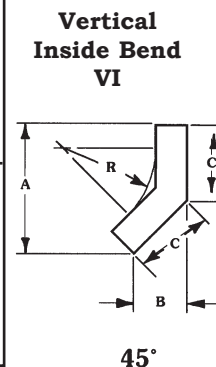
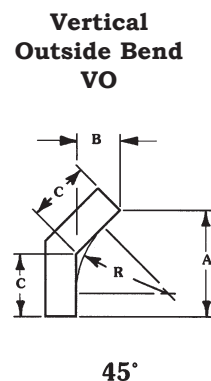

Note: Dimensions for reference only, when critical contact factory.
 Insert 'VO' for vertical outside bend or 'VI' for vertical inside bend.

4" Horizontal Tee & Cross

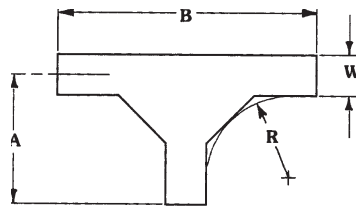

Tee

-R- Bend Radius in.	Tray Width in.	Horizontal Tee Dimensions		
		Catalog No.	A in.	B in.
12	6	* (Prefix)-06-HT12	22 1/4	44 1/2
	9	* (Prefix)-09-HT12	23 3/4	47 1/2
	12	* (Prefix)-12-HT12	25 1/4	50 1/2
	18	* (Prefix)-18-HT12	28 1/4	56 1/2
	24	* (Prefix)-24-HT12	31 1/4	62 1/2
	30	* (Prefix)-30-HT12	34 1/4	68 1/2
24	6	* (Prefix)-06-HT24	34 1/4	68 1/2
	9	* (Prefix)-09-HT24	35 3/4	71 1/2
	12	* (Prefix)-12-HT24	37 1/4	74 1/2
	18	* (Prefix)-18-HT24	40 1/4	80 1/2
	24	* (Prefix)-24-HT24	43 1/4	86 1/2
	30	* (Prefix)-30-HT24	46 1/4	92 1/2
36	6	(Prefix)-06-HT36	46 1/4	92 1/2
	9	(Prefix)-09-HT36	47 3/4	95 1/2
	12	(Prefix)-12-HT36	49 1/4	98 1/2
	18	(Prefix)-18-HT36	52 1/4	104 1/2
	24	(Prefix)-24-HT36	55 1/4	110 1/2
	30	(Prefix)-30-HT36	58 1/4	116 1/2
36	(Prefix)-36-HT36	61 1/4	122 1/2	

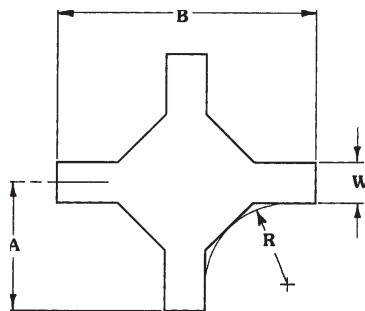

Cross

-R- Bend Radius in.	Tray Width in.	Horizontal Cross Dimensions		
		Catalog No.	A in.	B in.
12	6	* (Prefix)-06-HX12	22 1/4	44 1/2
	9	* (Prefix)-09-HX12	23 3/4	47 1/2
	12	* (Prefix)-12-HX12	25 1/4	50 1/2
	18	* (Prefix)-18-HX12	28 1/4	56 1/2
	24	* (Prefix)-24-HX12	31 1/4	62 1/2
	30	* (Prefix)-30-HX12	34 1/4	68 1/2
24	6	* (Prefix)-06-HX24	34 1/4	68 1/2
	9	* (Prefix)-09-HX24	35 3/4	71 1/2
	12	* (Prefix)-12-HX24	37 1/4	74 1/2
	18	* (Prefix)-18-HX24	40 1/4	80 1/2
	24	* (Prefix)-24-HX24	43 1/4	86 1/2
	30	* (Prefix)-30-HX24	46 1/4	92 1/2
36	6	(Prefix)-06-HX36	46 1/4	92 1/2
	9	(Prefix)-09-HX36	47 3/4	95 1/2
	12	(Prefix)-12-HX36	49 1/4	98 1/2
	18	(Prefix)-18-HX36	52 1/4	104 1/2
	24	(Prefix)-24-HX36	55 1/4	110 1/2
	30	(Prefix)-30-HX36	58 1/4	116 1/2
36	(Prefix)-36-HX36	61 1/4	122 1/2	

Note: Dimensions for reference only, when critical contact factory.

4" Horizontal Reducing Tee

Tray Width		Catalog No. *Insert radius (12" or 24")	12" Radius (All Molded)		24" Radius (All Molded)	
W1 in.	W2 in.		A in.	B in.	A in.	B in.
9	6	(Prefix)-09-06-HT*	23 3/4	44 1/2	35 3/4	68 1/2
12	6	(Prefix)-12-06-HT*	25 1/4	44 1/2	37 1/4	68 1/2
	9	(Prefix)-12-09-HT*	25 1/4	47 1/2	37 1/4	71 1/2
18	6	(Prefix)-18-06-HT*	28 1/4	44 1/2	40 1/4	68 1/2
	9	(Prefix)-18-09-HT*	28 1/4	47 1/2	40 1/4	71 1/2
	12	(Prefix)-18-12-HT*	28 1/4	50 1/2	40 1/4	74 1/2
24	6	(Prefix)-24-06-HT*	31 1/4	44 1/2	43 1/4	68 1/2
	9	(Prefix)-24-09-HT*	31 1/4	47 1/2	43 1/4	71 1/2
	12	(Prefix)-24-12-HT*	31 1/4	50 1/2	43 1/4	74 1/2
	18	(Prefix)-24-18-HT*	31 1/4	56 1/2	43 1/4	80 1/2
30	6	(Prefix)-30-06-HT*	34 1/4	44 1/2	46 1/4	68 1/2
	9	(Prefix)-30-09-HT*	34 1/4	47 1/2	46 1/4	71 1/2
	12	(Prefix)-30-12-HT*	34 1/4	50 1/2	46 1/4	74 1/2
	18	(Prefix)-30-18-HT*	34 1/4	56 1/2	46 1/4	80 1/2
	24	(Prefix)-30-24-HT*	34 1/4	62 1/2	46 1/4	86 1/2
36	6	(Prefix)-36-06-HT*	37 1/4	44 1/2	49 1/4	68 1/2
	9	(Prefix)-36-09-HT*	37 1/4	47 1/2	49 1/4	71 1/2
	12	(Prefix)-36-12-HT*	37 1/4	50 1/2	49 1/4	74 1/2
	18	(Prefix)-36-18-HT*	37 1/4	56 1/2	49 1/4	80 1/2
	24	(Prefix)-36-24-HT*	37 1/4	62 1/2	49 1/4	86 1/2
	30	(Prefix)-36-30-HT*	37 1/4	68 1/2	49 1/4	92 1/2

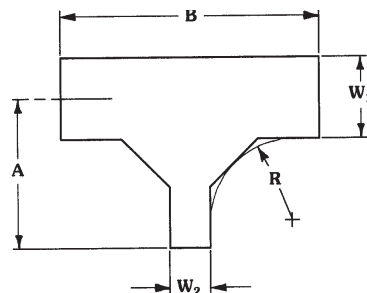
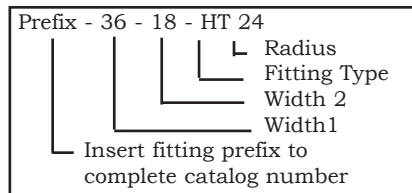

Tray Width		Catalog No.	36" Radius	
W1 in.	W2 in.		A in.	B in.
9	6	(Prefix)-09-06-HT36	47 3/4	92 1/2
12	6	(Prefix)-12-06-HT36	49 1/4	92 1/2
	9	(Prefix)-12-09-HT36	49 1/4	95 1/2
18	6	(Prefix)-18-06-HT36	52 1/4	92 1/2
	9	(Prefix)-18-09-HT36	52 1/4	95 1/2
	12	(Prefix)-18-12-HT36	52 1/4	98 1/2
24	6	(Prefix)-24-06-HT36	55 1/4	92 1/2
	9	(Prefix)-24-09-HT36	55 1/4	95 1/2
	12	(Prefix)-24-12-HT36	55 1/4	98 1/2
	18	(Prefix)-24-18-HT36	55 1/4	104 1/2
30	6	(Prefix)-30-06-HT36	58 1/4	92 1/2
	9	(Prefix)-30-09-HT36	58 1/4	95 1/2
	12	(Prefix)-30-12-HT36	58 1/4	98 1/2
	18	(Prefix)-30-18-HT36	58 1/4	104 1/2
	24	(Prefix)-30-24-HT36	58 1/4	110 1/2
36	6	(Prefix)-36-06-HT36	61 1/4	92 1/2
	9	(Prefix)-36-09-HT36	61 1/4	95 1/2
	12	(Prefix)-36-12-HT36	61 1/4	98 1/2
	18	(Prefix)-36-18-HT36	61 1/4	104 1/2
	24	(Prefix)-36-24-HT36	61 1/4	110 1/2
	30	(Prefix)-36-30-HT36	61 1/4	116 1/2

Note: Dimensions for reference only, when critical contact factory.

4" Horizontal Expanding Tee

Tray Width		Catalog No. *Insert radius (12" or 24")	12" Radius (All Molded)		24" Radius (All Molded)	
W1 in.	W2 in.		A in.	B in.	A in.	B in.
6	9	(Prefix)-06-09-HT*	22 1/4	47 1/2	34 1/4	71 1/2
	12	(Prefix)-06-12-HT*	22 1/4	50 1/2	34 1/4	74 1/2
	18	(Prefix)-06-18-HT*	22 1/4	56 1/2	34 1/4	80 1/2
	24	(Prefix)-06-24-HT*	22 1/4	62 1/2	34 1/4	86 1/2
	30	(Prefix)-06-30-HT*	22 1/4	68 1/2	34 1/4	92 1/2
9	36	(Prefix)-06-36-HT*	22 1/4	74 1/2	34 1/4	98 1/2
	12	(Prefix)-09-12-HT*	23 3/4	50 1/2	35 3/4	74 1/2
	18	(Prefix)-09-18-HT*	23 3/4	56 1/2	35 3/4	80 1/2
	24	(Prefix)-09-24-HT*	23 3/4	62 1/2	35 3/4	86 1/2
	30	(Prefix)-09-30-HT*	23 3/4	68 1/2	35 3/4	92 1/2
12	36	(Prefix)-09-36-HT*	23 3/4	74 1/2	35 3/4	98 1/2
	18	(Prefix)-12-18-HT*	25 1/4	56 1/2	37 1/4	80 1/2
	24	(Prefix)-12-24-HT*	25 1/4	62 1/2	37 1/4	86 1/2
	30	(Prefix)-12-30-HT*	25 1/4	68 1/2	37 1/4	92 1/2
18	36	(Prefix)-12-36-HT*	25 1/4	74 1/2	37 1/4	98 1/2
	24	(Prefix)-18-24-HT*	28 1/4	62 1/2	40 1/4	86 1/2
	30	(Prefix)-18-30-HT*	28 1/4	68 1/2	40 1/4	92 1/2
24	36	(Prefix)-18-36-HT*	28 1/4	74 1/2	40 1/4	98 1/2
	30	(Prefix)-24-30-HT*	31 1/4	68 1/2	43 1/4	92 1/2
36	(Prefix)-24-36-HT*	31 1/4	74 1/2	43 1/4	98 1/2	
30	36	(Prefix)-30-36-HT*	34 1/4	74 1/2	46 1/4	98 1/2

Tray Width		Catalog No.	36" Radius	
W1 in.	W2 in.		A in.	B in.
6	9	(Prefix)-06-09-HT36	46 1/4	95 1/2
	12	(Prefix)-06-12-HT36	46 1/4	98 1/2
	18	(Prefix)-06-18-HT36	46 1/4	104 1/2
	24	(Prefix)-06-24-HT36	46 1/4	110 1/2
	30	(Prefix)-06-30-HT36	46 1/4	116 1/2
9	36	(Prefix)-06-36-HT36	46 1/4	122 1/2
	12	(Prefix)-09-12-HT36	47 3/4	98 1/2
	18	(Prefix)-09-18-HT36	47 3/4	104 1/2
	24	(Prefix)-09-24-HT36	47 3/4	110 1/2
	30	(Prefix)-09-30-HT36	47 3/4	116 1/2
12	36	(Prefix)-09-36-HT36	47 3/4	122 1/2
	18	(Prefix)-12-18-HT36	48 1/4	104 1/2
	24	(Prefix)-12-24-HT36	48 1/4	110 1/2
	30	(Prefix)-12-30-HT36	48 1/4	116 1/2
18	36	(Prefix)-12-36-HT36	48 1/4	122 1/2
	24	(Prefix)-18-24-HT36	52 1/4	110 1/2
	30	(Prefix)-18-30-HT36	52 1/4	116 1/2
24	36	(Prefix)-18-36-HT36	52 1/4	122 1/2
	30	(Prefix)-24-30-HT36	55 1/4	116 1/2
36	(Prefix)-24-36-HT36	55 1/4	122 1/2	
30	36	(Prefix)-30-36-HT36	58 1/4	122 1/2

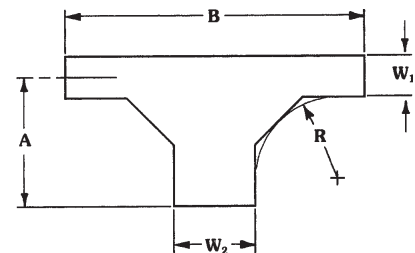
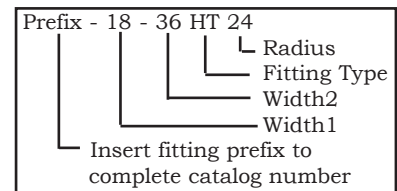

Note: Dimensions for reference only, when critical contact factory.

4" Horizontal Expanding/Reducing Cross

Tray Width		Catalog No. *Insert radius (12" or 24")	12" Radius (All Molded)		24" Radius (All Molded)	
W1 in.	W2 in.		A in.	B in.	A in.	B in.
6	9	(Prefix)-06-09-HX	22 1/4	47 1/2	34 1/4	71 1/2
	12	(Prefix)-06-12-HX	22 1/4	50 1/2	34 1/4	74 1/2
	18	(Prefix)-06-18-HX	22 1/4	56 1/2	34 1/4	80 1/2
	24	(Prefix)-06-24-HX	22 1/4	62 1/2	34 1/4	86 1/2
	30	(Prefix)-06-30-HX	22 1/4	68 1/2	34 1/4	92 1/2
9	36	(Prefix)-06-36-HX	22 1/4	74 1/2	34 1/4	98 1/2
	12	(Prefix)-09-12-HX	23 3/4	50 1/2	35 3/4	74 1/2
	18	(Prefix)-09-18-HX	23 3/4	56 1/2	35 3/4	80 1/2
	24	(Prefix)-09-24-HX	23 3/4	62 1/2	35 3/4	86 1/2
	30	(Prefix)-09-30-HX	23 3/4	68 1/2	35 3/4	92 1/2
12	36	(Prefix)-09-36-HX	23 3/4	74 1/2	35 3/4	98 1/2
	18	(Prefix)-12-18-HX	25 1/4	56 1/2	37 1/4	80 1/2
	24	(Prefix)-12-24-HX	25 1/4	62 1/2	37 1/4	86 1/2
	30	(Prefix)-12-30-HX	25 1/4	68 1/2	37 1/4	92 1/2
18	36	(Prefix)-12-36-HX	25 1/4	74 1/2	37 1/4	98 1/2
	24	(Prefix)-18-24-HX	28 1/4	62 1/2	40 1/4	86 1/2
	30	(Prefix)-18-30-HX	28 1/4	68 1/2	40 1/4	92 1/2
24	36	(Prefix)-18-36-HX	28 1/4	74 1/2	40 1/4	98 1/2
	30	(Prefix)-24-30-HX	31 1/4	68 1/2	43 1/4	92 1/2
30	36	(Prefix)-24-36-HX	31 1/4	74 1/2	43 1/4	98 1/2
	36	(Prefix)-30-36-HX	34 1/4	74 1/2	46 1/4	98 1/2

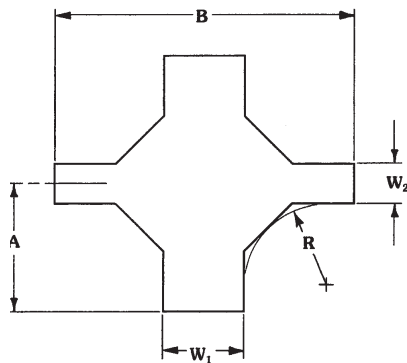

Tray Width		Catalog No.	36" Radius	
W1 in.	W2 in.		A in.	B in.
6	9	(Prefix)-06-09-HX36	46 1/4	95 1/2
	12	(Prefix)-06-12-HX36	46 1/4	98 1/2
	18	(Prefix)-06-18-HX36	46 1/4	104 1/2
	24	(Prefix)-06-24-HX36	46 1/4	110 1/2
	30	(Prefix)-06-30-HX36	46 1/4	116 1/2
9	36	(Prefix)-06-36-HX36	46 1/4	122 1/2
	12	(Prefix)-09-12-HX36	47 3/4	98 1/2
	18	(Prefix)-09-18-HX36	47 3/4	104 1/2
	24	(Prefix)-09-24-HX36	47 3/4	110 1/2
	30	(Prefix)-09-30-HX36	47 3/4	116 1/2
12	36	(Prefix)-09-36-HX36	47 3/4	122 1/2
	18	(Prefix)-12-18-HX36	49 1/4	104 1/2
	24	(Prefix)-12-24-HX36	49 1/4	110 1/2
	30	(Prefix)-12-30-HX36	49 1/4	116 1/2
18	36	(Prefix)-12-36-HX36	49 1/4	122 1/2
	24	(Prefix)-18-24-HX36	52 1/4	110 1/2
	30	(Prefix)-18-30-HX36	52 1/4	116 1/2
24	36	(Prefix)-18-36-HX36	52 1/4	122 1/2
	30	(Prefix)-24-30-HX36	55 1/4	116 1/2
30	36	(Prefix)-24-36-HX36	55 1/4	122 1/2
	36	(Prefix)-30-36-HX36	58 1/4	122 1/2

Note: Dimensions for reference only, when critical contact factory.

4" Reducers

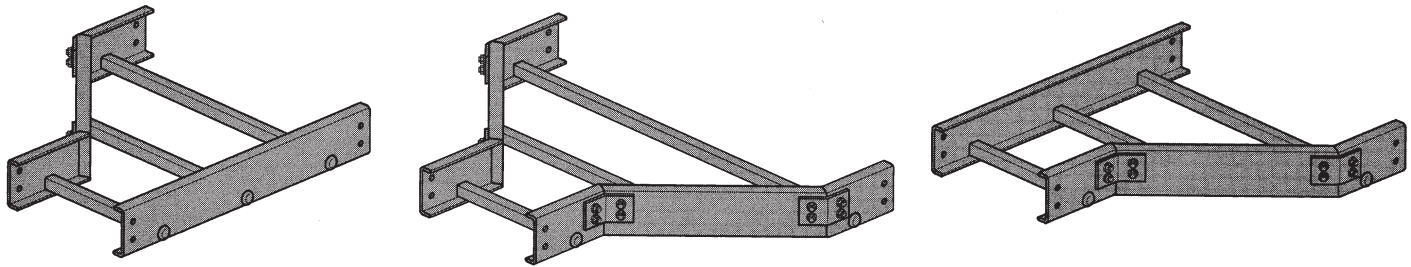

One pair of splice plates with SS6 hardware included.

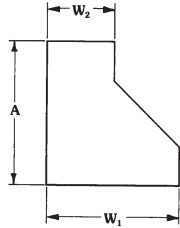

Left Hand Reducer

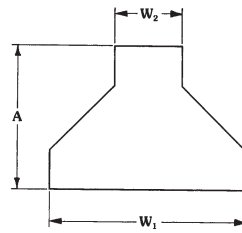

Straight Reducer

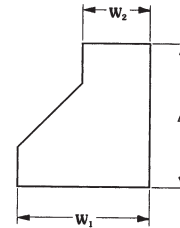

Right Hand Reducer

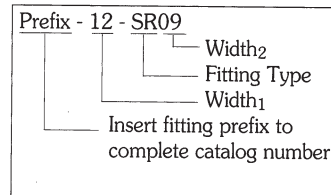

Tray Width		Left Hand Reducer		Straight Reducer		Right Hand Reducer	
W1 in.	W2 in.	Catalog No.	A in.	Catalog No.	A in.	Catalog No.	A in.
9	6	(Prefix)-09-LR06	17 1/2	(Prefix)-09-SR06	16	(Prefix)-09-RR06	17 1/2
12	6	(Prefix)-12-LR06	20 1/2	(Prefix)-12-SR06	17 1/2	(Prefix)-12-RR06	20 1/2
	9	(Prefix)-12-LR09	17 1/2	(Prefix)-12-SR09	16	(Prefix)-12-RR09	17 1/2
18	6	(Prefix)-18-LR06	26 1/2	(Prefix)-18-SR06	20 1/2	(Prefix)-18-RR06	26 1/2
	9	(Prefix)-18-LR09	23 1/2	(Prefix)-18-SR09	19	(Prefix)-18-RR09	23 1/2
	12	(Prefix)-18-LR12	20 1/2	(Prefix)-18-SR12	17 1/2	(Prefix)-18-RR12	20 1/2
24	6	(Prefix)-24-LR06	32 1/2	(Prefix)-24-SR06	23 1/2	(Prefix)-24-RR06	32 1/2
	9	(Prefix)-24-LR09	29 1/2	(Prefix)-24-SR09	22	(Prefix)-24-RR09	29 1/2
	12	(Prefix)-24-LR12	26 1/2	(Prefix)-24-SR12	20 1/2	(Prefix)-24-RR12	26 1/2
	18	(Prefix)-24-LR18	20 1/2	(Prefix)-24-SR18	17 1/2	(Prefix)-24-RR18	20 1/2
30	6	(Prefix)-30-LR06	38 1/2	(Prefix)-30-SR06	26 1/2	(Prefix)-30-RR06	38 1/2
	9	(Prefix)-30-LR09	35 1/2	(Prefix)-30-SR09	25	(Prefix)-30-RR09	35 1/2
	12	(Prefix)-30-LR12	32 1/2	(Prefix)-30-SR12	23 1/2	(Prefix)-30-RR12	32 1/2
	18	(Prefix)-30-LR18	26 1/2	(Prefix)-30-SR18	20 1/2	(Prefix)-30-RR18	26 1/2
	24	(Prefix)-30-LR24	20 1/2	(Prefix)-30-SR24	17 1/2	(Prefix)-30-RR24	20 1/2
36	6	(Prefix)-36-LR06	44 1/2	(Prefix)-36-SR06	29 1/2	(Prefix)-36-RR06	44 1/2
	9	(Prefix)-36-LR09	41 1/2	(Prefix)-36-SR09	28	(Prefix)-36-RR09	41 1/2
	12	(Prefix)-36-LR12	38 1/2	(Prefix)-36-SR12	26 1/2	(Prefix)-36-RR12	38 1/2
	18	(Prefix)-36-LR18	32 1/2	(Prefix)-36-SR18	23 1/2	(Prefix)-36-RR18	32 1/2
	24	(Prefix)-36-LR24	26 1/2	(Prefix)-36-SR24	20 1/2	(Prefix)-36-RR24	26 1/2
	30	(Prefix)-36-LR30	20 1/2	(Prefix)-36-SR30	17 1/2	(Prefix)-36-RR30	20 1/2

Note: Dimensions for reference only, when critical contact factory.

4" Vertical Tees

Vertical Tee Down

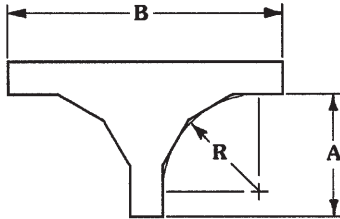

Vertical Tee Up

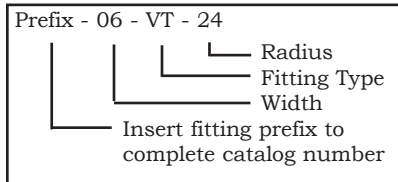
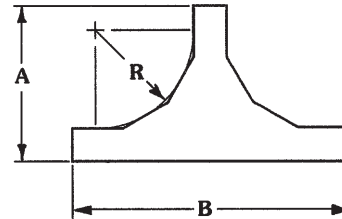

Two pair of splice plates with SS6 Hardward included.

-R- Bend Radius in.	Tray Width in.	Catalog No.	Vertical Tee			
			Vertical Tee Down		Vertical Tee Up	
			A in.	B in.	A in.	B in.
12	6	* (Prefix)-06-(*)12	19 1/4	42 1/2	23 1/4	42 1/2
	9	* (Prefix)-09-(*)12				
	12	* (Prefix)-12-(*)12				
	18	* (Prefix)-18-(*)12				
	24	* (Prefix)-24-(*)12				
	30	* (Prefix)-30-(*)12				
36	* (Prefix)-36-(*)12					
24	6	(Prefix)-06-(*)24	31	66	35	66
	9	(Prefix)-09-(*)24				
	12	(Prefix)-12-(*)24				
	18	(Prefix)-18-(*)24				
	24	(Prefix)-24-(*)24				
	30	(Prefix)-30-(*)24				
36	(Prefix)-36-(*)24					
36	6	(Prefix)-06-(*)36	43	90	47	90
	9	(Prefix)-09-(*)36				
	12	(Prefix)-12-(*)36				
	18	(Prefix)-18-(*)36				
	24	(Prefix)-24-(*)36				
30	(Prefix)-30-(*)36					

Note: Dimensions for reference only, when critical contact factory.